



Beijing Multifit Electrical Technology Co.,Ltd



MULTIFIT GROUP

0086-13641024477

0086-010-87227420
0086-0754-81888658

multifit@multifitele.com

Multifit



<http://vmaxpowerpv.com>
<http://www.multifitsolar.com>
<http://www.multifitele.com>

Right & Left Solar Cleaning Robot

Sunshine for you Multifit to all

广东众能光伏设备有限公司

GUANGDONG MULTIFIT SOLAR CO.,LTD

► Company introduction



Multifit Solar is a high-tech manufacturer which is mainly dedicated to research and development, produce, sale and construct of solar power systems and other green energy.



60⁺ Patents
20⁺ CE Certificates
20⁺ Software Copyright



3GWP
In Total



Stock Exchange
280768
2009 Multifit Establish

Our cleaning equipments include solar panel tracking cleaning robots, track-mounted fully automatic walking solar cleaning trolley, the third generation four-wheel drive mode of the solar cleaning robot with stronger cross-barrier ability, crawler-type upper and lower cleaning robot and semi-automatic photovoltaic cleaning brush for civil power stations.

Our cleaning robots realize the remote intelligent control and have many functions: automatic avoidance function to prevent the robot from slipping, automatic rectify correction mechanism and automatic adjustment to prevent the machine from deviation, running tilt, jamming, and good obstacle surmounting performance to surmount certain slopes, steps, and dislocations.

Also, a new intelligent management cloud platform for remote photovoltaic panel cleaning robot has been set up in our robot. And our cleaning robot has our own unique technology in intelligent cleaning of photovoltaic panels by robots, automatic detection, tracking and positioning, group communication and control functions, as well as the establishment of an intelligent management platform with multi-terminal control.

In the future, Multifit will be continually committing to improve the renewable energy industry and develop more efficient and cost-effective solar cleaning solutions.

MULTIFIT

► The importance of cleaning solar power station

As a new clean energy, solar power generation is developing rapidly all over the world. The global installed capacity had over 150 GW in 2021, and it is predicted that the global cumulative installed capacity will reach to 1870 GW by 2025. 

Since solar power stations are usually built in places with high terrain, sufficient sunshine, strong wind and lack of water resources, it is easy to accumulate sand and dirt on solar panels. If the dust and dirt are not removed in time, the power generation efficiency will be seriously affected by 8% to 30%. The hot spot problem on the pv panels caused by dust also greatly reduces the service life.



► Solar Robot Development



Multifit Solar had set up Smart Remote Control and Management Cloud Platform for our patent cleaning robot. In the process of intelligent cleaning, robots can automatically detect, track, locate, communicate and control groups, to meet the demands of different kinds of devices control and management.

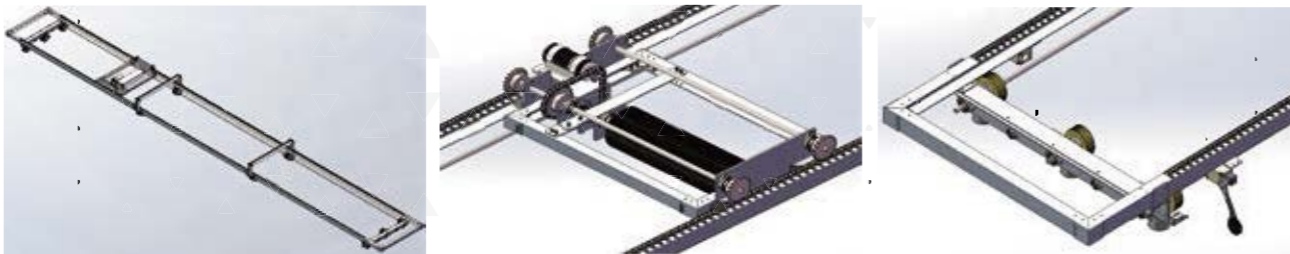

In order to solve above problems, Multifit Solar had developed many different kinds of cleaning robots suitable for different solar power stations. Its included Tracking Solar Cleaning Robot, Right & Left Solar Cleaning Robot, Up & Down Solar Cleaning Robot, Shuttle Solar Robot Transfer Vehicle, Semi-Automatic Solar Cleaning Brush, etc.



► Original Manufacturer



► Product Features

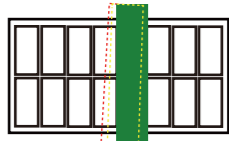

Automatic Adjustment:

Automatically correct and adjust to prevent machine deviation and jamming

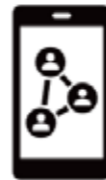

Intelligent control Internet of things technology application:

Independent control, grouping, Control by mobile, automatic cleaning time and cleaning mode can be set

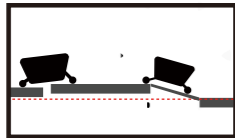

Stronger Obstacle-crossing Ability :

Including slope, step and misalignment, etc. Capable of spanning over 50mm misalignment of flat or end faces.



Lightweight equipment ≈30kg:

The whole machine is about 30kg, which is more than 30% lighter than similar products, and it is convenient to carry.

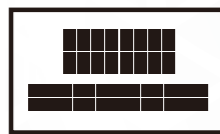

Strong adaptability:

Applicable to various arrangement arrays and various power stations.



Solar power system:

Self-charging-comes with a solar power system, convenient and efficient, can last 4-6 hours.



1min disassembly and assembly of brushes:

Applicable to various arrangement arrays and various power stations.



Ambient temperature:

-10°C (Unfrozen) ~50°C



Adjusting the brush up and down:

When the brush wears out, the cleaning ability decreases. You can adjust the brush downward to increase the cleaning ability and double the service life of the brush.

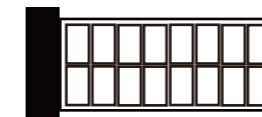

Danger avoidance:

Automatic edge sensing technology to prevent the robot from sliding down and avoid danger



Self-sensing mode:

Intelligent opening and cleaning mode in rainy days.

Main Features

Core Features

Intelligent Control

- Automatic adjustment: Automatic correction and adjustment during running, to prevent machine deviation and jamming.
- Stronger obstacle crossing ability: Include slope, step and misalignment.
- Excellent running property: Work with lithium battery and brushless motor, more durable.
- High efficient cleaning: 360° rolling brush, one day can clean 1.2MWp.
- Auto start and stop: Full automatic remote control of running and back to docking station.
- Integrated dry and watering clean: To meet different cleaning requirement of different solar power plants.
- Competitive Cost: Quick money return by increasing the electricity production.

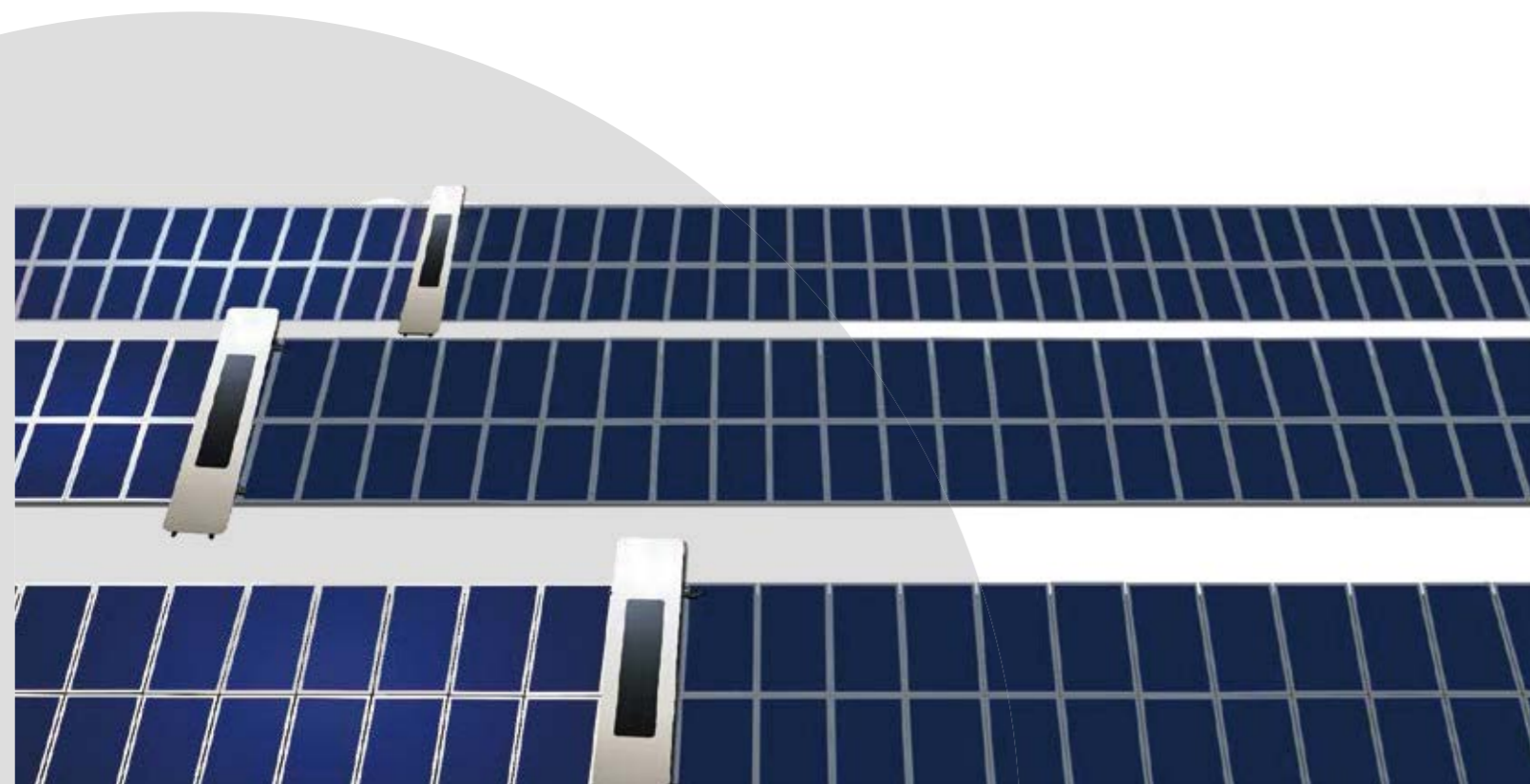

► Product Advantage

The second generation cleaning robot has more advantages than the robots on the market in terms of performance, product design, intelligent control, etc., such as portability, long life, intelligent APP controller, and easy to disassemble, install, adjust and maintain brushes.

► Product Details

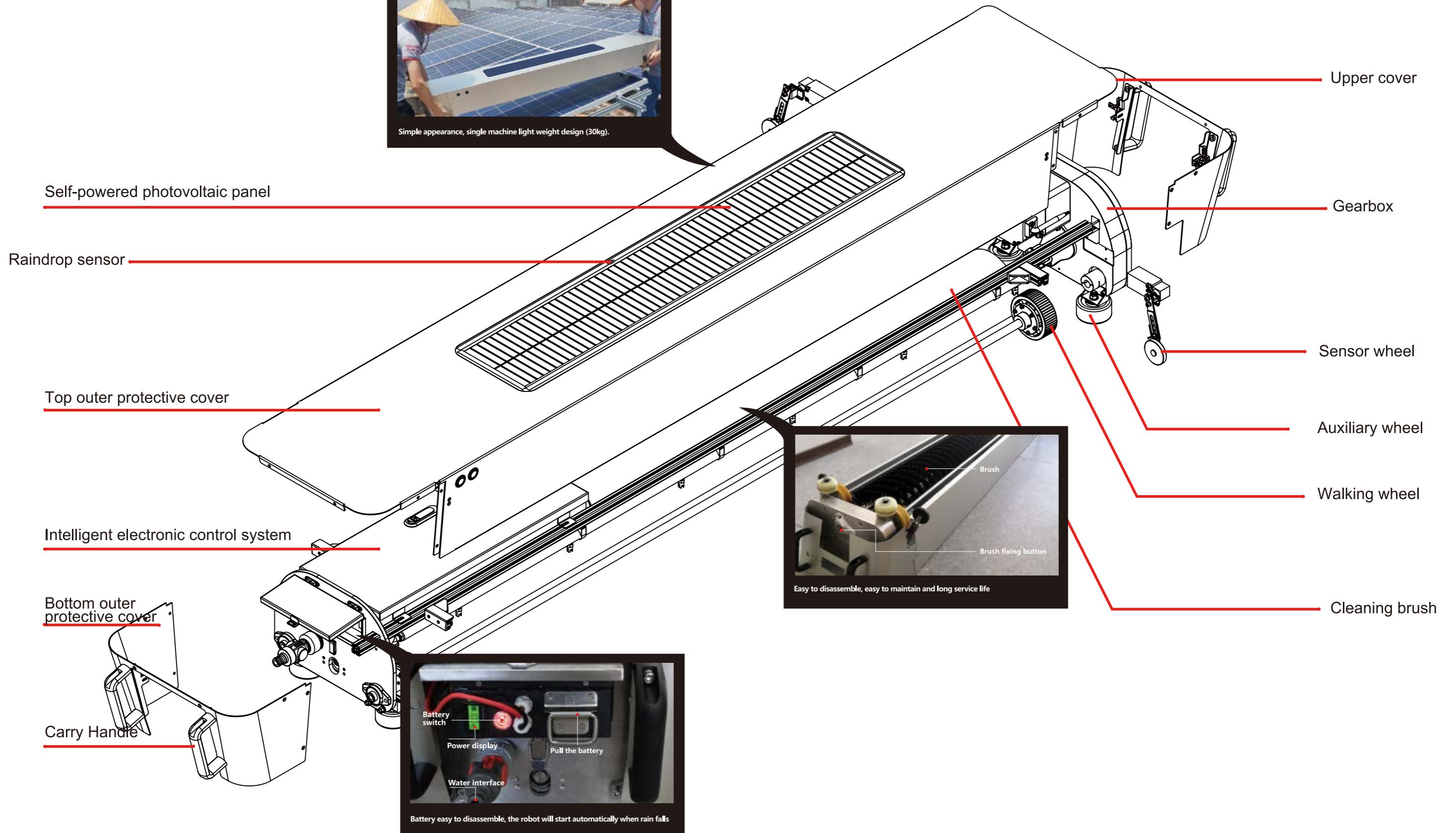

► Solar panel cleaning robot - Dry cleaning



MULTIFIT Solar Panel Cleaning Robot in GuangDong

▶ APP Platform & Remote Controller



Start at any time, stop at any time, scrub repeatedly, where there is no network, you can use the remote control to start and operate the solar panel cleaning robot

Smart Management Control System

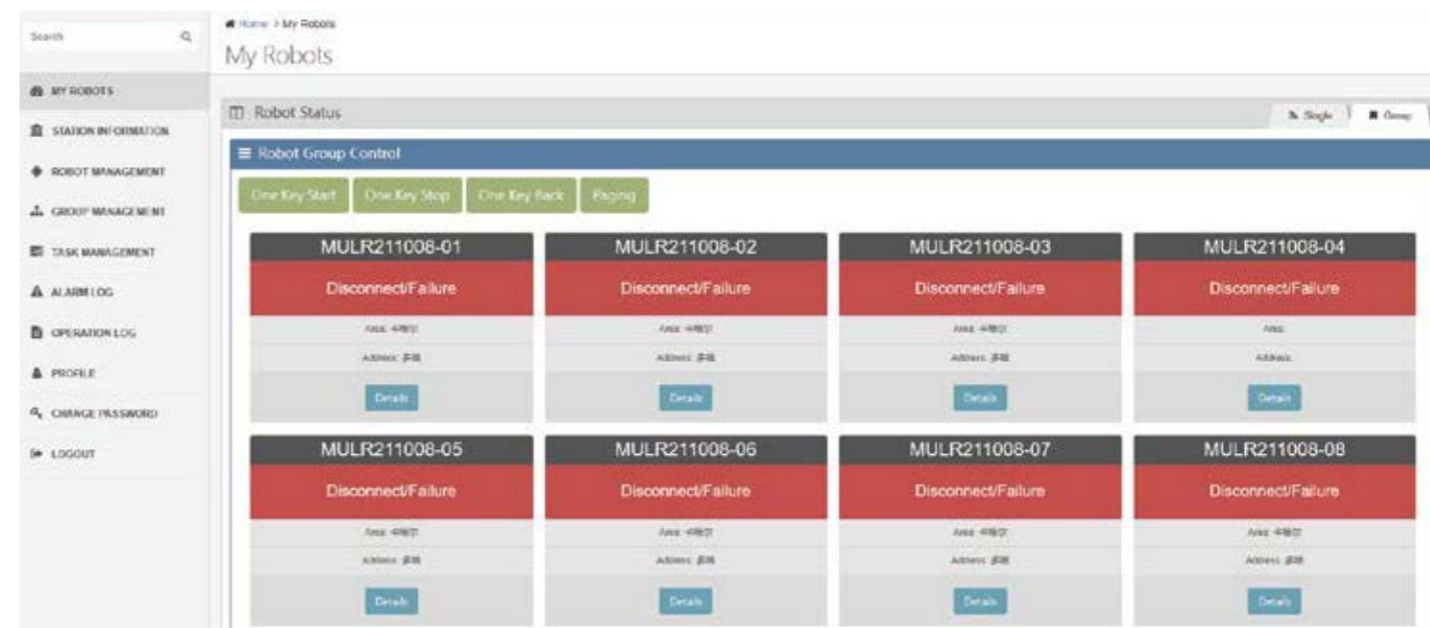
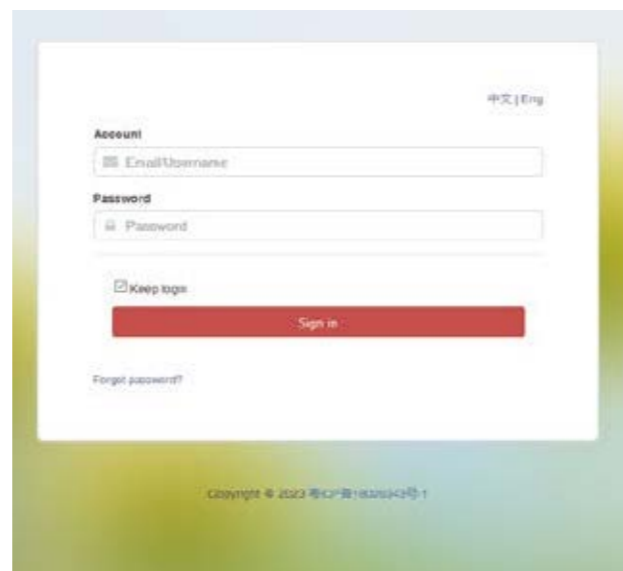

MULTIFIT platform:

1. Fully automatic.
2. No need for you to be on site.
3. Multiple cleaning robots work simultaneously.

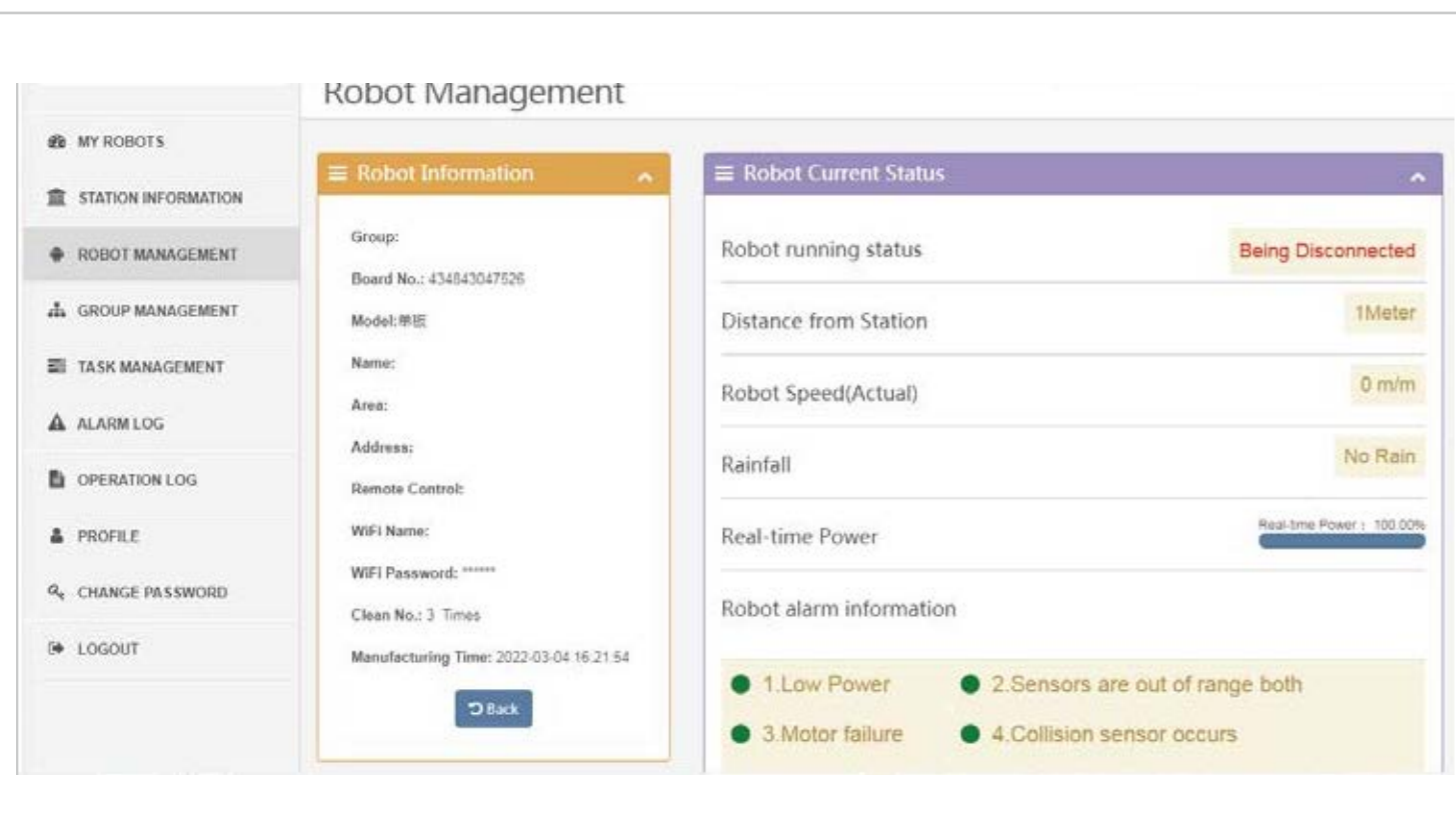

		Processed	Unprocessed								Status	Operate
#	No.	Model	Power Station	Robot Area	Fault Type	Fault Status	Fault Time	Content				
<input type="checkbox"/>	28388	434843047526		BJ	Robot	Pending	2022-06-22 17:00:52	The robot exceeds the response time, it is judged to be offline (Connect time : 2022-06-22 15:58:08)	Pending	Processed		
<input type="checkbox"/>	28281	434843047526		BJ	Robot	Pending	2022-06-17 11:02:41	The robot exceeds the response time, it is judged to be offline (Connect time : 2022-06-17 09:44:55)	Pending	Processed		
<input type="checkbox"/>	28275	434843047526		BJ	Robot	Pending	2022-06-16 17:29:31	The robot exceeds the response time, it is judged to be offline (Connect time : 2022-06-16 17:25:47)	Pending	Processed		
<input type="checkbox"/>	28274	434843047526		BJ	Robot	Pending	2022-06-16 17:26:52	The robot exceeds the response time, it is judged to be offline (Connect time : 2022-06-16 14:41:05)	Pending	Processed		
<input type="checkbox"/>	28273	434843047526		BJ	Robot	Pending	2022-06-16 14:35:02	The robot exceeds the response time, it is judged to be offline (Connect time : 2022-06-16 10:16:29)	Pending	Processed		
<input type="checkbox"/>	28083	434843047526		BJ	Robot	Pending	2022-05-24 11:03:04	The robot exceeds the response time, it is judged to be offline (Connect time : 2022-05-24 09:36:54)	Pending	Processed		
<input type="checkbox"/>	27920	434843047526		BJ	Robot	Pending	2022-05-09 17:16:37	The robot exceeds the response time, it is judged to be offline (Connect time : 2022-05-09 17:01:41)	Pending	Processed		
<input type="checkbox"/>	27893	434843047526		BJ	Robot	Pending	2022-05-	The robot exceeds the response time, it is judged	Pending	Processed		

► Technical Parameters MR-G1 Series

Technical Data	MR-G1 Series		
PV Module Length Range (mm)	Single PV Panel from 990mm to 2384mm	Double PV Panel from 990mm to 2384mm	Three PV Panel from 990mm to 2384mm
Obstacle Crossing Ability (mm)	20	20	20
Traveling Distance(m)	One-way travel distance from 3600~4320M (12m/min)	One-way travel distance from 2280~3600 M (12m/min)	One-way travel distance from 1800~2700M (12m/min)
Traveling Speed(m/min)	12~20	12~20	12~20
Generator Power(W)	100W/200W	200W/300W	300W
Weight of Machine(Kg)	30~50	40~95	60~115
Width of Machine(mm)	365	365	365
Height of Machine(mm)	280	280	280
Length of Machine (Customized according to pv panel size)	1410 ~ 2804mm (gap 20)	2420~ 5208mm (gap 20)	3430 ~ 7612mm (gap 20)
Water Used Per Hour	270L/H (0.3mpa)	330L/H (0.3mpa)	360L/H (0.3mpa)
Solar Panel(W)	27W		
Battery Capacity(Ah)	24V/10Ah	24V/20Ah	24V/20Ah
Working Time(Hours)	4~6 Hours		
Brush Life(Years)	2~3 Years		
Applicable Temperature (°C)	-10°C (Unfrozen) ~50°C		
Cleaning Mode	Dry/Watering Cleaning		
Cleaning Way	One Time/Repeated Time/Positioning/Schedule		
Other Functions	Speed Adjust/Direction Adjust		
Optional Configuration	Bridge Mounting Rail		
	Water Washing Device		
	Wireless Remote Controller		
	Webpage/Phone Apps Monitoring & Control		
	WiFi Module/4G Module		
	Robot Group Control Module		

► Project



► Solar panel cleaning robot - Washing



► Group Control & Management Solution



► Project



► RECRUITMENT TO JOIN



Multifit Solar Cleaning Robot - Model



MULTIFIT
众能力电

► Qualification Certification

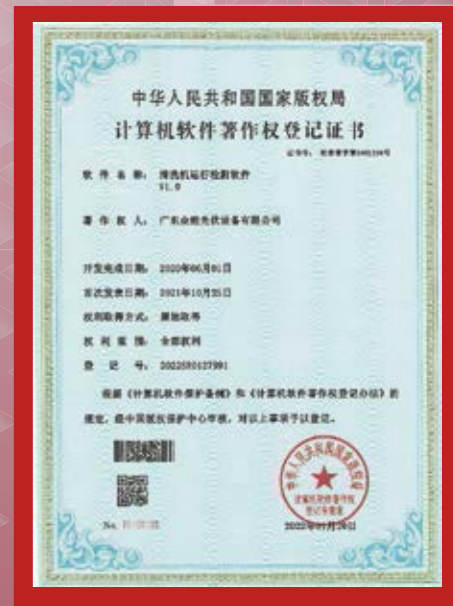

Multifit The Most Every Ray of Sunshine

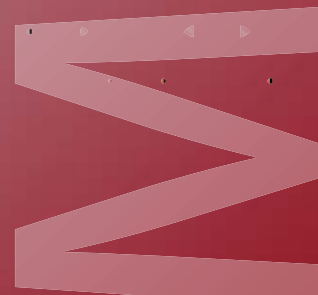

► Qualification Certification

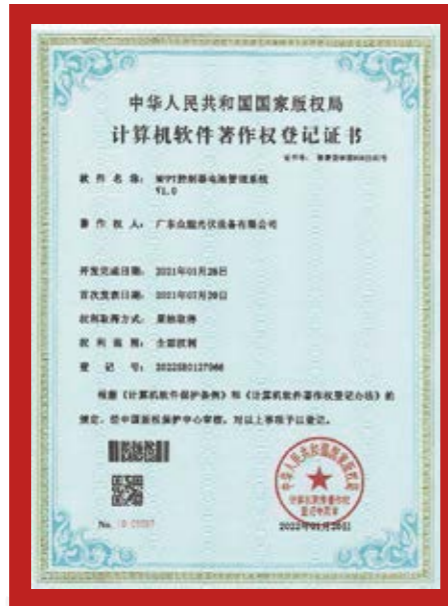
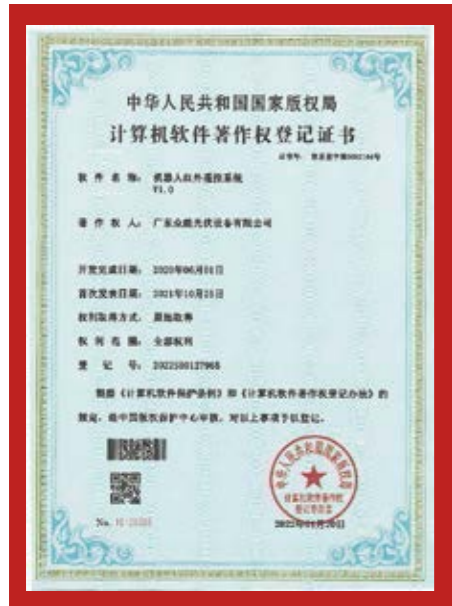

- Beijing Headquarter:503-No.5 RongHuaGuoJi Building.No.10 Courtyard. Ronghua South Rd.BDA Zone 100176,BeiJing China
- Guangdong Plant: 3/F,JieSi Bldg.,6 Keji West Road,Hi-Tech Zone 515041,Shantou,Guangdong,China
- Shenzhen Branch:Rm1213,ChenshishanHai Bluding.No.51 PingXin North Rd.LongGang District.ShenZhen City GuangDong Province.China.

